

# AUTOMATION SYSTEMS

## MOTOR FOR SLIDING GATE

Assembly manual for the installer

**DTM-SWIFT624**  
ver 1.0





**AUTOMATION MUST BE CARRIED OUT IN THE COMPLIANCE WITH EUROPEAN NORMS:**

**EN 12100-1/2** (Safety of machinery. Electrical machinery equipment. General requirements)

**EN 12445-2000** (Gates. Safety in use of power operated doors. Test methods)

**EN 12453** (Gates. Safety in use of power operated doors. Requirements)

✍ The installer should deliver the RCD (residual-current device) with the device. It secures the break of the electric circuit of the devices from the power supply. Standards require separating contacts for at least 3 mm in every pole (EN 60335-1)

✍ Automatic wing gates should be compliant with the norms as well as with every applicable local regulation.

✍ The electrical installation to which automation is being connected must be compliant with applicable standards and must be made correctly.

## PLEASE START FROM READING IMPORTANT SAFETY RULES!



Non-observance and not-abiding remarks with these symbols can lead to the accident resulting in injury of people or material damage. Please become acquainted with these warnings. Gate drive ensures correct and safe operation only when installed and used according to the given safety rules. DTM System is not responsible for accidents resulting from incorrect usage or non-professional installation of the devices.



During assembly or repair works of the automatic gate caution shall be exercised, **do not wear jewellery, watches or loose clothes.**



Gate should always move without any obstruction. The gate which jams or deadlocks must be repaired immediately by the professional specialist not independently.



Power cables must be arranged according to local regulations concerning the construction and electrical installations. Electric cables shall be connected only to properly earthed network and only by the authorised electro tech service specialist.



Additional equipment should be kept away from children. Do not allow children to operate control buttons or remote control. It is important to remember that automatic gate is such a device that it is impossible to eliminate the risk of serious injury completely in the case of remote operation uncontrolled by adult . Controlling units should allow for visual verification of the gate itself and its surroundings.



**Remove possibly installed locks from the gate to avoid the damage.**



After installation it is necessary to check if the mechanism is correctly set and if the device, security system and emergency unlocking operate correctly.



While performing maintenance such as cleaning, greasing etc. gate automation must be disconnected from the network. It is necessary to provide the device for switching off all phases with the use of the switch (the distance between the contacts min. 3mm) or separate fuses.



The drive cannot be started and operate if there is a wicket in the gate and this wicket is not closed properly.



It is necessary to lock or limit possible move of the gate towards the wall (ex. by installing the gate stops). It eliminates the possibility of crushing while opening the gate.



Please make sure that the persons installing, maintaining or operating gate automation follow these instructions. It is necessary to keep these instructions in such a place that they are easy to find when needed.



The systems protecting against crushing or injury (ex. photocell systems) must work correctly after installing and connecting the drive to the network.

### Warranty

DTM System provides operational and ready to use devices and gives 24 months warranty from the selling date to the end customer. This time is counted according to the producer warranty labels or serial numbers placed on every product. DTM System obliges itself to repair the device for free if during the warranty period there are problems which come because of its fault. Broken device should be supplied on customer's expense to the place of purchase and enclose clear and brief description of the breakage. The cost of mount/dismount is covered by the user. The warranty does not cover any faults caused by improper usage, user self repairs, regulations and adaptations, lightning strikes, voltages or short circuits in the electrical grid. Appropriate legal acts regulate details of the warranty.

# 1. Introduction

## 1.1. Basic information

The electromechanical drive is intended to control sliding gates. The assembled and working system can be comfortably operated by radio transmitters. **It should be checked whether we have all elements from picture 1, and next read the entire instruction manual.**

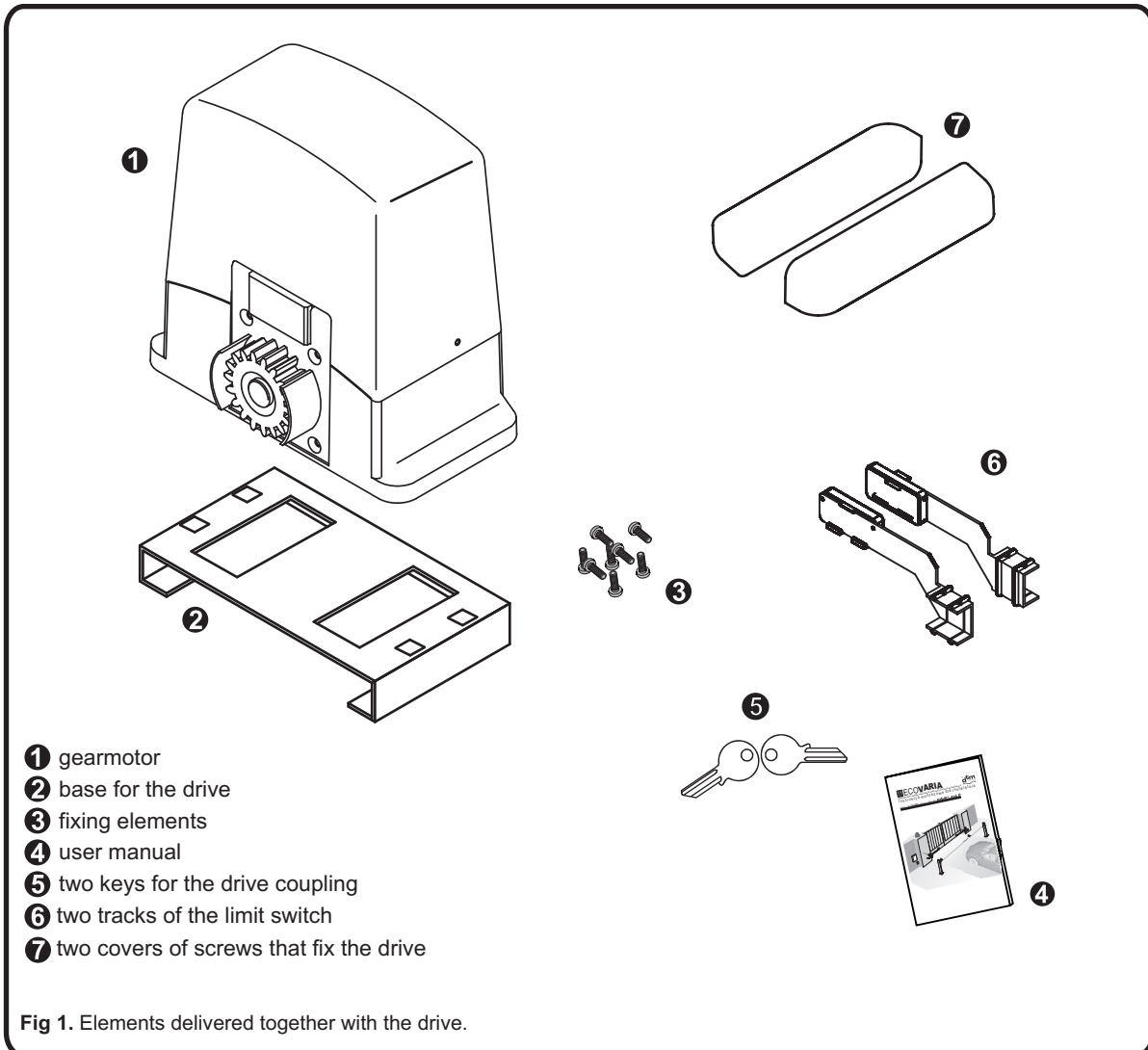

## 1.2. DTM-SWIFT6 technical data

• case material	aluminium with plastics elements
• network power supply(motor)	230VAC 50Hz/24VDC
• engine electricity consumption	8A
• power consumption	250W
• maximum gate weight	600kg.
• protection class	IP-44
• thermal protection	140°C
• leaf motion speed	10-16m/min
• drawbar pull	600N
• motor rotation speed	1400 r/min
• operation intensity	50% h (30 cycles/h)
• temperature range	-20°C to +55°C
• motor weight	10 kg.

## 2. Mechanical assembly

### 2.1. Workplace preparation

Correct installation requires appropriate preparation of workplace. Examining the gate system is an essential activity and it should meet the following requirements::

- ▶ **The driving mechanism requires the place which will not expose it to flooding.** If the place does not meet this condition, it is necessary to change it in order to comply with this requirement!
- ▶ **Check if the gate opens and closes smoothly.**

#### Gate parameters which influence system operation:

- ▶ **Gate dimensions:** Gate dimension is an important factor. Big rolling resistances (motion resistances) can cause braking of the gate, significantly increasing the power required for its motion
- ▶ **Gate weight:** Gate weight is given in the technical data of the drive and it is an estimated parameter. However the maximum allowed weight of the gate must not be exceeded.
- ▶ **Temperature influence:** Low outdoor temperatures can hamper or make it impossible to start (changes in ground, snow, ice, etc.)
- ▶ **Service frequency/starting time:** Drives have the maximum turn-on time of about 50% (30 cycles) within an hour.

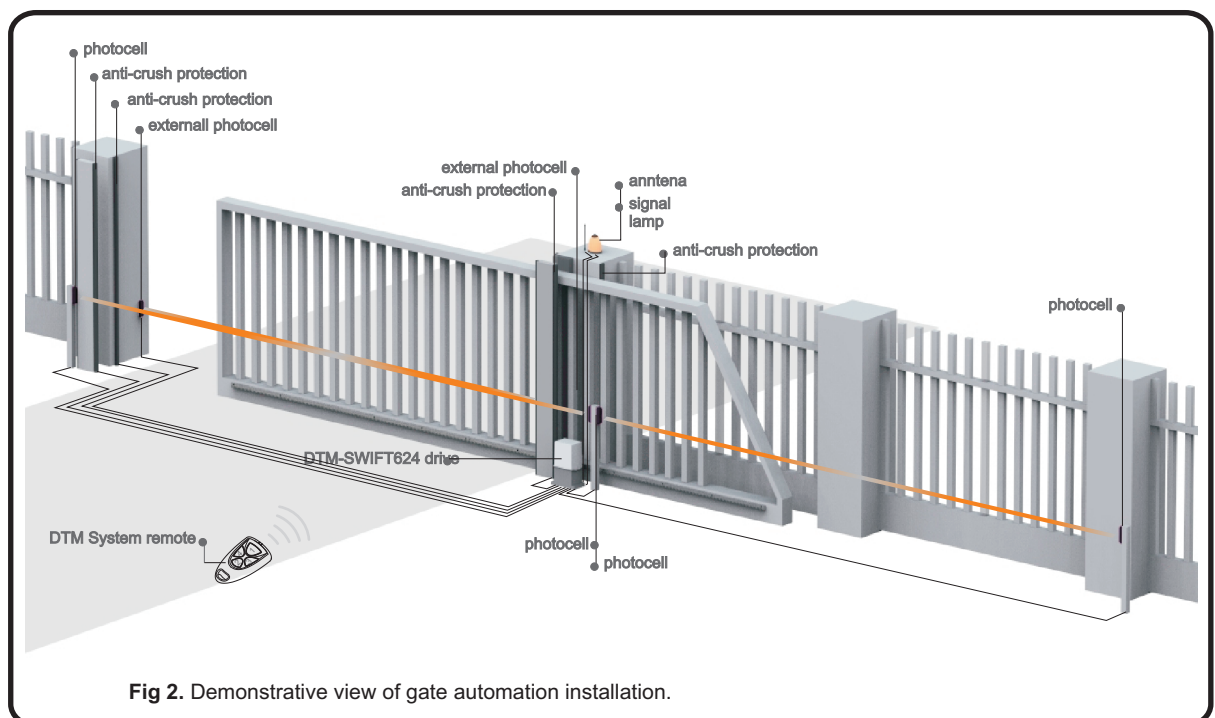

Fig 2. Demonstrative view of gate automation installation.

#### CAUTION!

The drive cannot cause the deadlock of the gate on permanent elements of the structure. Correctly placed limit switches of the motor stop the gate before it meet the resistance by outermost positions (backlash remains between the gear and gear rack when the gate is closed or opened). Not observance of this recommendation can cause motor damaging and loss of the warranty!

#### CAUTION!

Drives were not designed for constant action with their maximum turn-on time (continuous work). The drive becomes too hot and turns off until it reaches the start temperature. The outdoor temperature and gate parameters are important factors which affect the real turn-on time.

#### CAUTION!

Gate motion must be regular, without impact, not blocked by anything.





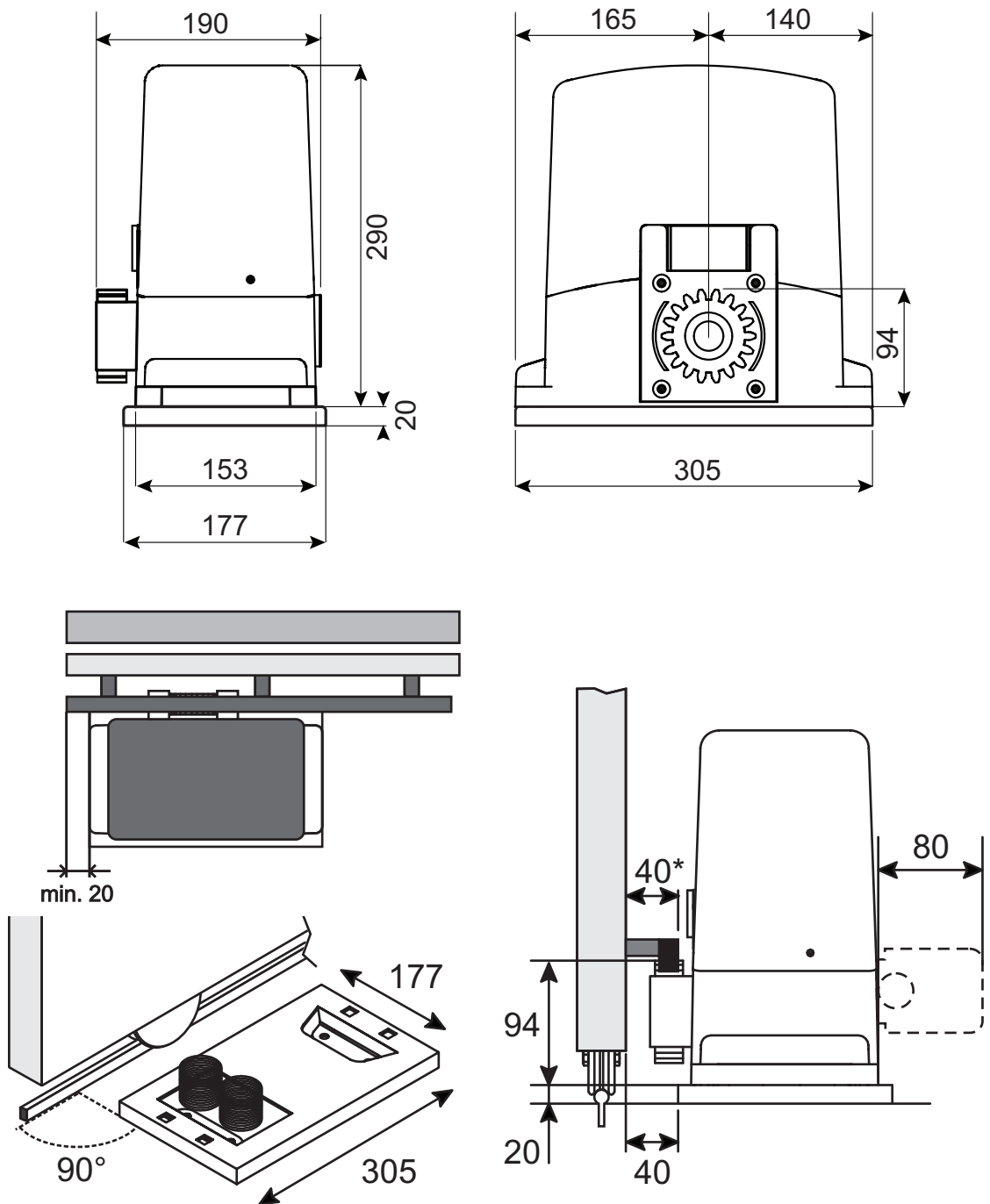

Fig 4. Drive dimensions and recommended assembly dimensions (mm).

**2.3. Base for the drive**

**Appropriate putting of the base is decisive for the subsequent assembly of this drive and gate operation.**

Determining the distance between the point of the ratchet turnover and the surface of gear rack fixing (Fig.4), and next the heights of the base surface to the edge of the rakes. The dimensions can differ depending on the type of the rack. Before ultimate assembly dimensions are specified, it is absolutely necessary to check, whether assembling the drive is possible (enough space for assembly tools).

Drives in gate installations influence the base with great powers. Therefore after determining the best dimensions, it is best to weld the base directly to the gate structure. In case of stone or concrete foundations, we fix the base in such a way that locating pins do not loosen themselves while operating.



## 2.8. Drive assembly

Unlock the drive (see pt 2.11). Place unlocked drive on the base and screw it using delivered screws and nuts. If a centre hole is used for conducting the wiring, before installing electrical conduit and cables must be inserted.

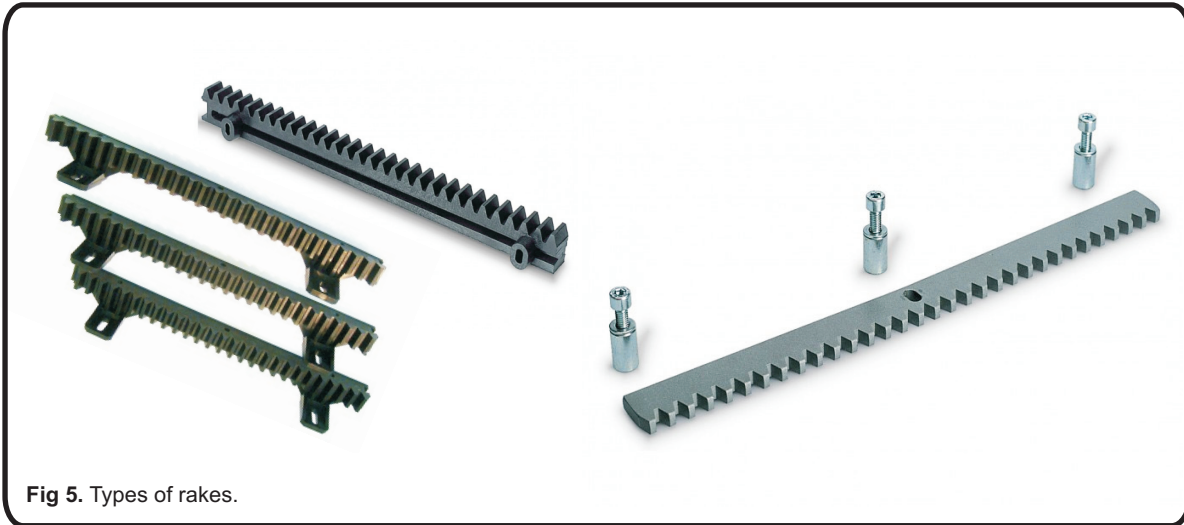

Fig 5. Types of rakes.

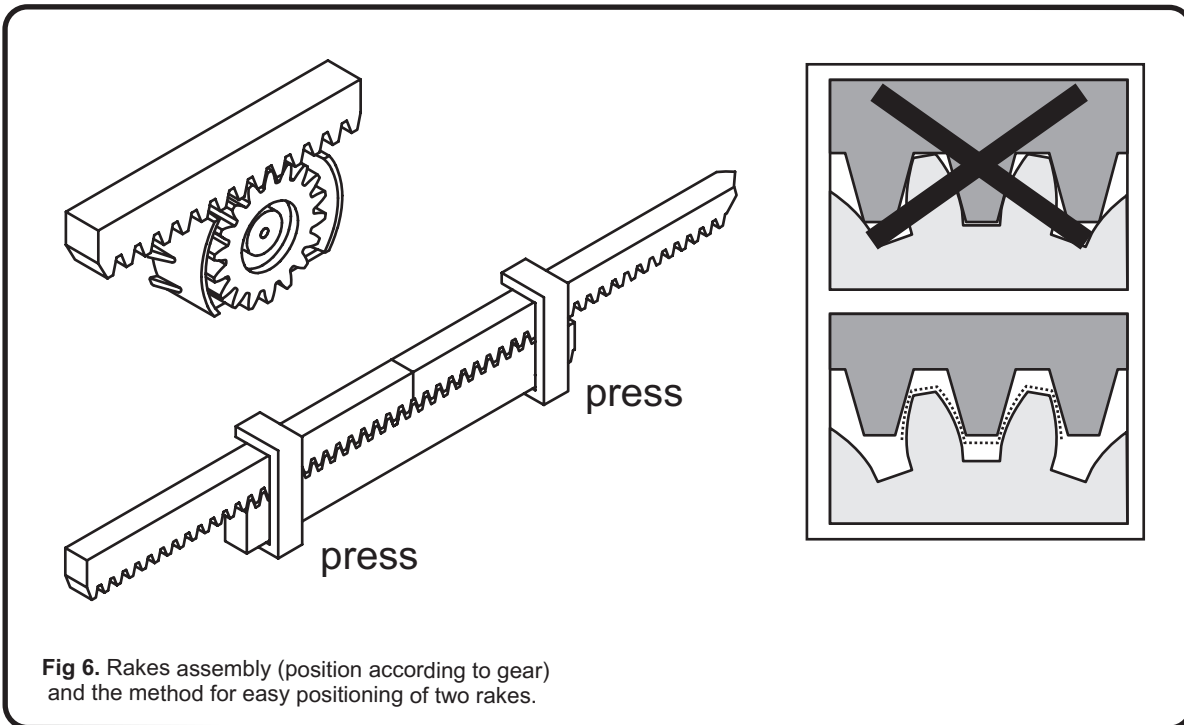

Fig 6. Rakes assembly (position according to gear) and the method for easy positioning of two rakes.

## 2.9. Rakes assembly

Depending on possessed rakes (picture 5) and structure of the gate they should be screwed or, if there is such need, threaded spacers should be welded on and next screw rakes to them. It is possible to make the assembly easier by applying the third rake as the support (picture 6).

## 2.10. Limit switches assembly

Preliminary assembly is made before first starting of the drive so that the appropriate limit switch is activated before the gate reaches outermost positions. Starting the gate without the presence of limit switches can lead to damaging the drive and/or the gate in the moment of crossing one of allowed outermost positions..

## 2.11. Locking and unlocking the drive

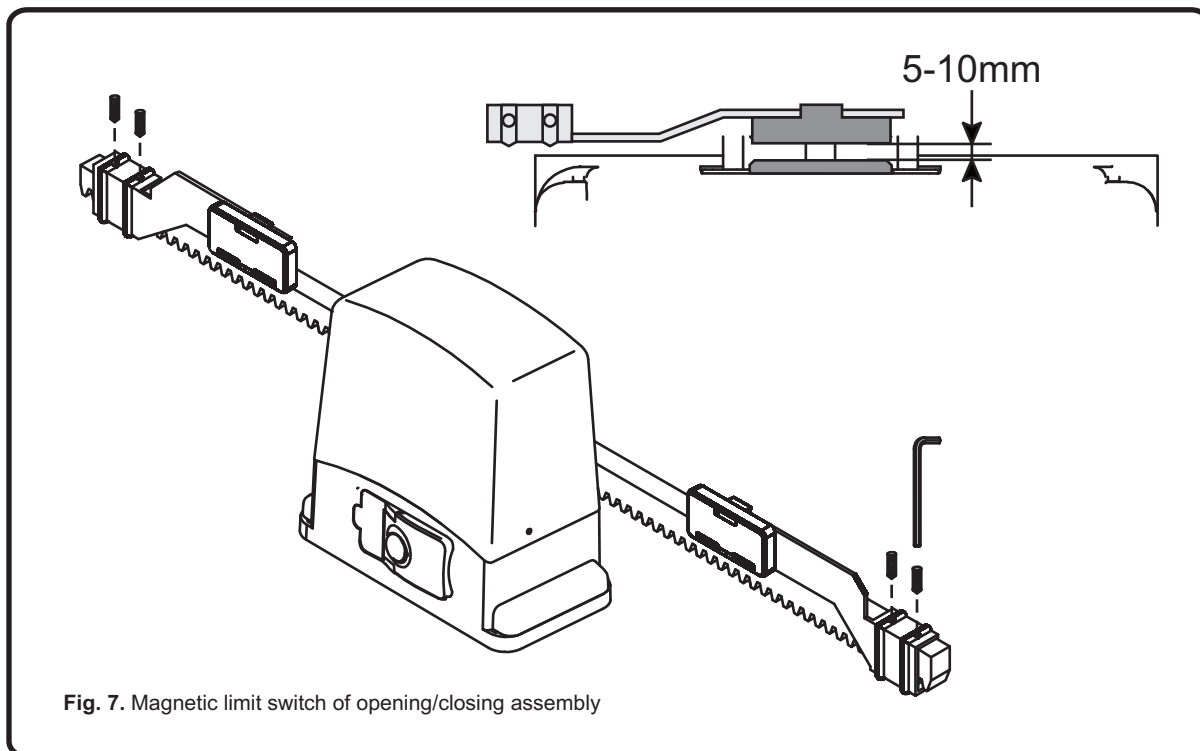

It is possible to unlock the driving mechanism in case of the breakdown or lack of the power supply. Next, the gate can be manually-operated. In order to unlock the drive, turn the key in the station and push the coupling lever. After locking / unlocking the drive, cover the place for the key with the special plug attached to the set. In order to lock the drive act in the reverse order: insert the key to the station, turn the coupling lever so that entire lever disappears in hollow intended for it.

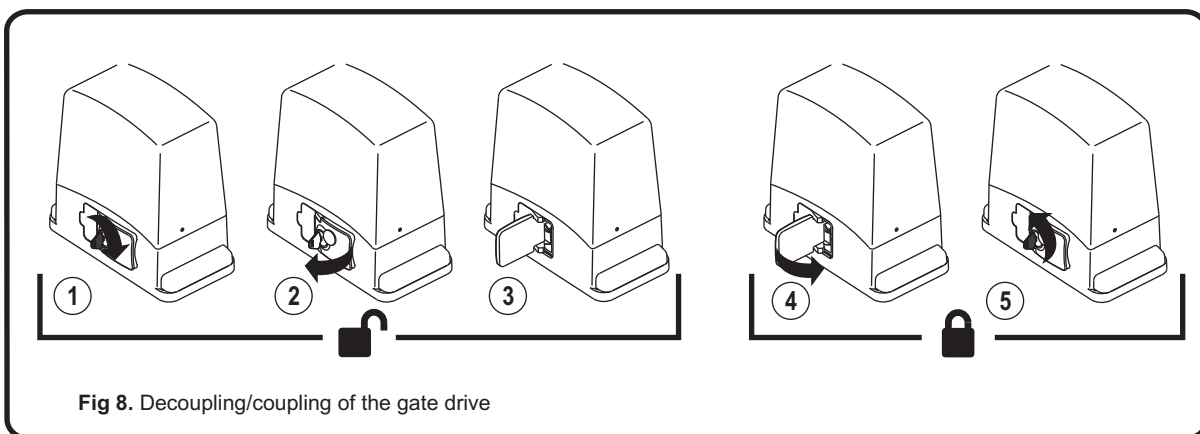

**Before first start after locking the drive move the gate manually to the moment when you hear characteristic "click" of the drive mechanism.** This action significantly increases life of coupling elements.

### 2.12 Maintenance

Mechanics of the drive does not require maintenance. However, it is advised to check if the drive is fixed in the safe way in regular intervals (especially at the beginning of the use e.g. every month) . Unlock the drive and check if the gate works correctly. Remember that the drive cannot eliminate problems caused by the badly operating gate.

## 3. Electrical installation

### IMPORTANT REMINDER

Electrical installations and automations of the drive must be made by experienced and trained staff under effective laws and regulations. Dangerous voltage 230V 50Hz appear in the devices, all connections should be made at the voltage switched off. Installer's task is to install the system safely enough to minimize the risk associated with using it. Person who makes the installation without observing the applicable regulations is responsible for the possible damage which can be caused by the device.

#### 3.1. Preparing the elements of electrical installation

**WIRING** - The basic configuration of wiring is compatible with picture 9. Before the purchase of wiring check you have a photocell with the built-in optical indicator, then we must predict two additional conductors in wires for photocells. The length of wiring depends on the length of the gate, width and height of the posts and the place predicted for junction boxes, therefore estimate the length of the wires independently. Spreading the wiring is presented visually in picture 2. Connect the start capacitor inside the driver, next to steering electronics. It is also necessary to use protective corrugated tubes for wires.

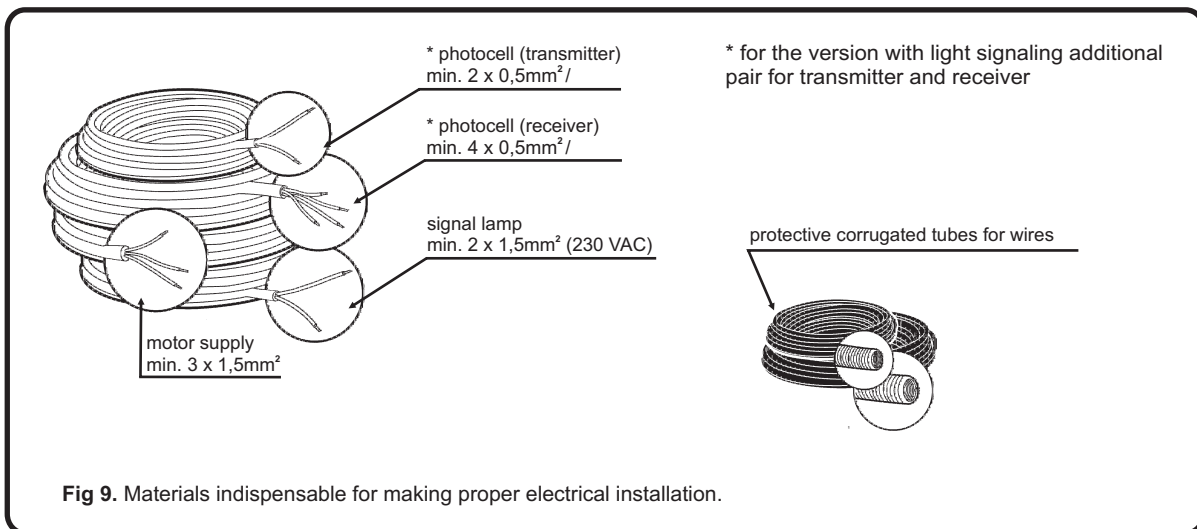

Fig 9. Materials indispensable for making proper electrical installation.

#### 3.2. Connecting the devices to the driver

Connecting devices to the driver should be the last installation activity made according to manual attached to control unit. Firstly install the motor, arrange needed cables and fasten photocells. During the assembly of the installation master switch cutting off the network voltage must be used. Remember that moisture and water destroy electronic devices, it is necessary to protect the driver against these factors. All holes and bushes of cables must be sealed in order to keep the desirable degree of the IP protection.

### CAUTION!

**Electrical installations and automations of the drive must be made by experienced and trained staff under effective laws and regulations..**



## 4. Acceptance tests

### **CAUTION!**

After installing the driver and all cooperating devices, especially safety devices, it is necessary to perform final tests to check the entire automation. These tests should be executed by the competent staff, being aware of existing threats! Final tests are the most important phase at the realization of automation. Individual components such as engine, photocells, etc, can require specific control and for this reason it is recommended to execute checking procedures included in manuals of given components.

### **CAUTION!**

Gate, both while opening and closing, should affect the motor with equal resistance. The surface of the gate should be set in position to the ground in such way so that while opening and closing the gate the resistances do not diversify as a result of gravity.





**EU DECLARATION OF CONFORMITY**

No.13/2016

**Manufacturer**DTM System spółka z ograniczoną odpowiedzialnością spółka komandytowa  
ul.Brzeska 7, PL 85-145 Bydgoszcz**Product**Electromechanical drive,  
Type: DTM-SWIFT6, DTM-SWIFT624**Product description**

The product designed for moving sliding gates. Powered by 230VAC, 50Hz.

**The product is compatible with European Union Directives:**

2006/42/UE, 2014/35/UE, 2014/30/UE

**The product is compatible with harmonised standards:**

EN ISO 12100:2012	Safety of machinery. General requirements
EN ISO 13857:2010	Safety of machinery, safety distances
EN 60335-1:2012	Household electrical appliances. General requirements
EN 60335-2-9:2007	Household electrical appliances. Detailed requirements
EN 12453:2002	Safety in use of power operated door
EN 55014-1:2012	Electromagnetic Compatibility – emission
EN 55014-2:2015-06	Electromagnetic Compatibility – immunity
EN 61000-3-2:2014-10	Electromagnetic Compatibility - levels
EN 61000-3-3:2013-10	Electromagnetic Compatibility – levels
EN 62233:2008	Measurement methods for electromagnetic fields

**Conformity assessment procedure**

EN 12445-2002 Gates. Safety in use of power operated doors. Test methods. If the device is installed and maintained according to all the guidelines given by the manufacturer in compliance with this norm then the automation system is compliant with 2006/42/EC Machinery Directive

05-10-2016r. Bydgoszcz, **Poland**Chairman of the board  
of general partner  
Daniel Kujawski**CAUTION!**

The presented symbol informs that this electrical or electronic device cannot be removed with everyday waste after its exploitation. The device must be given to the specialized collection point. Detailed information concerning the nearest collection point are accessible at local authorities. Moreover, the product can be given to the local distributor while purchasing similar device. The correct recycling of devices gives the possibility of keeping natural resources of the Earth prevents negative impact on health and environment which can be endangered by inappropriate handling of waste.





design and production  
of electronic devices  
gate automation